

# MEM09204A

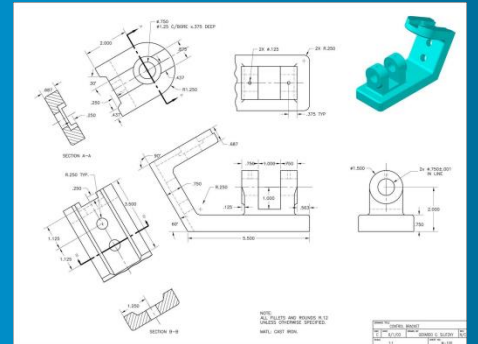

Produce basic engineering detail drawing

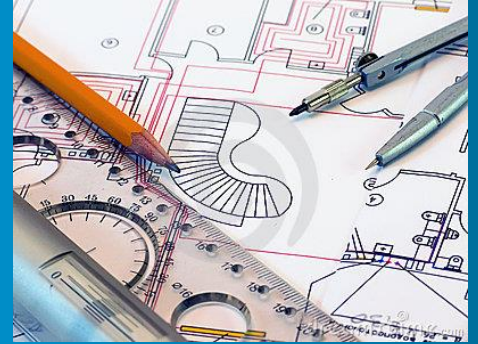
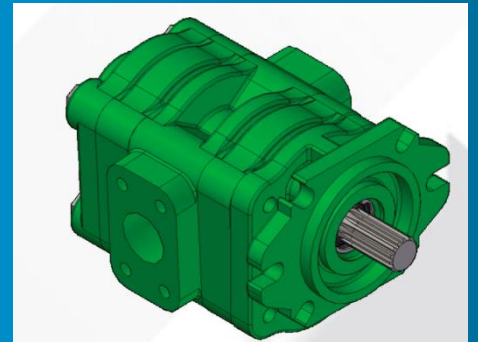

## Contents:

<b>Conditions of Use:</b> .....	<b>3</b>
Unit Resource Manual.....	3
Manufacturing Skills Australia Courses .....	3
<b>Feedback:</b> .....	<b>4</b>
<b>Aims of the Competency Unit:</b> .....	<b>5</b>
<b>Unit Hours:</b> .....	<b>5</b>
<b>Prerequisites:</b> .....	<b>5</b>
<b>Elements and Performance Criteria</b> .....	<b>6</b>
<b>Required Skills and Knowledge</b> .....	<b>7</b>
<b>Topic Program:</b> .....	<b>8</b>
<b>Contents:</b> .....	<b>9</b>
<b>Topic 1 – Drawing Standards &amp; Projection:</b> .....	<b>14</b>
Required Skills: .....	14
Required Knowledge: .....	14
Standards - General Information: .....	14
Australian Drawing Standards: .....	16
Manual Drafting Equipment: .....	17
Drawing Media: .....	20
Types of Lines:.....	21
Orthogonal Projection: .....	22
<i>Third Angle Projection:</i> .....	<i>23</i>
<i>First Angle Projection:</i> .....	<i>23</i>
<i>Number of Views:</i> .....	<i>24</i>
Determining the Front View: .....	25
Skill Practice Exercises: .....	26
<b>Topic 2 – Laying Out an Engineering Drawing:</b> .....	<b>40</b>
Required Skills: .....	40
Required Knowledge: .....	40
Drawing Layout:.....	40
Locating Difficult Points: .....	43
Skill Practice Exercises: .....	44
<b>Topic 3 – Drawing Sheets:</b> .....	<b>48</b>
Required Skills: .....	48
Required Knowledge: .....	48
Standard Drawing Sheet Sizes: .....	48
<i>ISO A Series:</i> .....	<i>48</i>
<i>Oversized ISO A Sheets:</i> .....	<i>49</i>
<i>ISO B Series</i> .....	<i>49</i>
<i>ISO C Series:</i> .....	<i>49</i>
<i>Rolled Paper</i> .....	<i>50</i>
Layout of Drawing Sheets:.....	50
<i>Borders:</i> .....	<i>50</i>

<i>Grid Reference:</i> .....	50
<i>Camera Alignment Marks:</i> .....	51
<i>Title Block:</i> .....	51
<i>Revision Block:</i> .....	53
<i>Material/Parts/Cutting List:</i> .....	53
Skill Practice Exercise: .....	55
<b>Topic 4 – Dimensioning:</b> .....	<b>56</b>
Required Skills: .....	56
Required Knowledge: .....	56
Historical Measurements: .....	56
Dimensions: .....	56
Features of a Dimension: .....	57
<i>Dimension Line:</i> .....	57
<i>Projection Lines:</i> .....	57
<i>Dimension Text:</i> .....	57
<i>Arrows:</i> .....	57
<i>Projection Line Extension:</i> .....	57
<i>Gap:</i> .....	57
<i>Leader Line:</i> .....	57
Dimension drawn “Not to Scale”: .....	58
Placement of Dimensions: .....	58
Types of Dimensioning: .....	60
<i>Chain:</i> .....	60
<i>Running:</i> .....	60
<i>Datum or Baseline:</i> .....	<b>Error! Bookmark not defined.</b> 60
<i>Radial Aligned:</i> .....	61
<i>Radial Horizontal:</i> .....	61
Rules Governing Dimensioning: .....	61
Skill Practice Exercises: .....	64
<b>Topic 5 – Sections:</b> .....	<b>74</b>
Required Skills: .....	74
Required Knowledge: .....	74
Section Overview .....	74
Cutting Plane Line: .....	75
Hatching Patterns: .....	75
<i>Hatching of Single Part:</i> .....	76
<i>Hatching of Adjacent Parts:</i> .....	76
<i>Thin Areas:</i> .....	77
Full Section: .....	77
Offset Section: .....	77
Half Section: .....	78
Aligned Section: .....	78
Broken-Out Section (Part or Local): .....	78
Revolved Section: .....	78
Removed Section: .....	79
Interposed Section: .....	79
Shafts and Fasteners in Section: .....	79
Webs and Ribs in Section: .....	80
Holes in Flanges: .....	80
Rules for Sectioning: .....	81
Skill Practice Exercises: .....	81
<b>Topic 6 – Auxiliary Views:</b> .....	<b>92</b>
Required Skills: .....	92
Required Knowledge: .....	92
Overview: .....	92
Drawing an Auxiliary View: .....	93

Circular Features: .....	96
Draw an Ellipse in an Auxiliary View: .....	96
Reverse Construction: .....	98
Skill Practice Exercises: .....	99
<b>Topic 7 – Lettering: .....</b>	<b>103</b>
Required Skills: .....	103
Required Knowledge: .....	103
Lettering Overview .....	103
Why Practice Lettering? .....	103
Lettering: .....	104
<i>Uniformity: .....</i>	<i>104</i>
<i>Strength of lines: .....</i>	<i>104</i>
Technique of Lettering: .....	104
Guide Lines: .....	105
Height and Proportion of Letters: .....	106
Spacing of Letters and Words: .....	106
Skill Practice Exercises: .....	107
<b>Topic 8 – Scales: .....</b>	<b>109</b>
Required Skills: .....	109
Required Knowledge: .....	109
Scale Overview: .....	109
Metric Scales: .....	109
Imperial Scales: .....	110
Reading Scale Rules: .....	110
Recommended Scales: .....	112
Skill Practice Exercises: .....	113
<b>Topic 9 – Geometric Construction: .....</b>	<b>115</b>
Required Skills: .....	115
Required Knowledge: .....	115
History of Geometric Construction: .....	115
Definitions: .....	116
Straight Line Geometric Construction Methods: .....	118
Geometric Construction Methods Using Tangency: .....	131
Constructing Hexagons Using Geometric Construction Methods: .....	140
Divide a Line into Equal Parts Using Geometric Construction Methods: .....	149
Divide a Circle into Equal Parts Using Geometric Construction Methods: .....	150
Skill Practice Exercises: .....	152
<b>Topic 10 – Assembly Drawings: .....</b>	<b>161</b>
Required Skills: .....	161
Required Knowledge: .....	161
General: .....	161
General Arrangement Drawings .....	161
Assembly Drawings: .....	163
Detail Assembly Drawings: .....	164
Detail Drawing: .....	166
Fabrication Drawings .....	167
Features of an Assembly Drawing: .....	168
<i>Parts List: .....</i>	<i>168</i>
<i>Balloons or Cross Referencing: .....</i>	<i>169</i>
<i>Dimensions: .....</i>	<i>169</i>
<i>Tabulation: .....</i>	<i>170</i>
How Do The Parts Fit Together? .....	171
Skill Practice Exercises: .....	173

<b>Topic 11 – Detail Drawings:</b>	<b>178</b>
Required Skills:	178
Required Knowledge:	178
Detail Drawing Procedure:	178
Detail Drawings:	178
Creating a Detail Drawing:	179
<i>Detail Drawings from Engineer’s Sketches:</i>	<i>179</i>
<i>Details Lifted from Design Drawings:</i>	<i>179</i>
Completing a Detail Drawing:	180
Skill Practice Exercises:	182
<b>Topic 12 – General Tolerance Dimensions:</b>	<b>183</b>
Required Skills:	183
Required Knowledge:	183
Lesson Aim:	183
Tolerance Dimensioning:	183
Methods of Expressing Tolerance:	184
<i>Unilateral Tolerance:</i>	<i>184</i>
<i>Bilateral Tolerance:</i>	<i>184</i>
<i>Limit of Size:</i>	<i>184</i>
<i>AutoCAD Terminology:</i>	<i>185</i>
<i>Fundamentals for Tolerance Selection</i>	<i>185</i>
<i>Tolerance for Linear Dimensions:</i>	<i>185</i>
<i>Tolerance for Angular Dimensions:</i>	<i>186</i>
<i>Tolerance for Holes and Shafts:</i>	<i>186</i>
<i>Number of Decimal Points:</i>	<i>187</i>
Convert Unilateral and Bilateral Tolerances to Limit of Size Tolerances:	187
Datum Dimensioning:	187
<i>Datum Edges/Surfaces:</i>	<i>188</i>
Review Questions: MEM09204-RQ-01	189
Skill Practice Exercises:	191
<b>Topic 13 – Surface Finish Indication:</b>	<b>194</b>
Required Skills:	194
Required Knowledge:	194
Surface Finish:	194
Finished Surface Symbols:	194
<i>Machining Mandatory:</i>	<i>194</i>
<i>Machining Optional:</i>	<i>194</i>
<i>Machining Not Permitted:</i>	<i>194</i>
Proportions of Surface Symbols:	195
Surface Roughness:	195
<i>Specifying Surface Roughness Value:</i>	<i>196</i>
<i>Surface Lay Pattern:</i>	<i>196</i>
<i>Material Removal Allowance:</i>	<i>196</i>
<i>Symbol for Special Requirements:</i>	<i>196</i>
Location of Surface Finish Symbols on Drawings:	197
Review Questions: MEM09005-RQ-02	191
Skill Practice Exercises:	199
<b>Topic 14 – Geometric Tolerance:</b>	<b>201</b>
Required Skills:	201
Required Knowledge:	201
<i>Definition:</i>	<i>201</i>
Geometric Tolerancing:	201
Basic Dimensional Symbol:	203
Datum Identifying Symbol:	203
<i>Supplementary Symbols:</i>	<i>230</i>
<i>Combined Symbols:</i>	<i>203</i>

---

Explanation of Characteristic Symbols: .....	204
Placing the Symbols Using AutoCAD: .....	207
Review Questions: MEM09005-RQ-03 .....	209
Skill Practice Exercises: .....	212
<b>Practice Competency Test.....</b>	<b>214</b>

## Topic 1 –Drawing Standards & Projection:

### Required Skills:

On completion of the session, the participants will be able to:

- Produce a simple drawing in Orthogonal Projection.
- Use different line constructions to identify features on an orthogonal view..

### Required Knowledge:

- Australian Standard controlling the preparation and presentation of all drawings in Australia.
- The difference between First and Third Angle Projection.
- Manual and computerised drafting equipment.
- Types of line construction and line widths used in preparing a drawing.

### Standards - General Information:

The preparation of plans for the construction of buildings and machines is as old as written history. Original drawings were carved on rock or sketched onto papyrus. One of the oldest drawings of an engineering component is a cave painting of a bow in Castellon, France in about 8000BC. As civilisation grew and the skills became more advanced, plans were produced on other mediums such as bark and paper using a variety of instruments to assist in creating better quality drawings.



Figure 1.1

Figure 1.1 shows a detail drawing of various halls, rooms and antechambers around the central courtyard of the Palace of Nur Adad in Larsa, Babylon around 1865 to 1850BC and was drawn in clay. Although there is no writing on the tablet, we can be sure of what it depicts. Firstly, it is written on the characteristic purplish Larsa clay. Secondly, the design of the palace and the proportions correspond almost exactly with the building remains of the Nur Adad temple unearthed by a French excavations that started in 1903. So far the only example of an identifiable plan of a known building on a clay tablet.

Figure 1.2 shows Leonardo De Vinci’s drawing of a helicopter (1490-1500). Though the first actual helicopter wasn’t built until the 1940s, it is believed that Leonardo da Vinci’s sketches from the late fifteenth century were the predecessor to the modern day flying machine. As with many of da Vinci’s ideas, he never actually built and tested it – but his notes and drawings mapped out exactly how the device would operate.

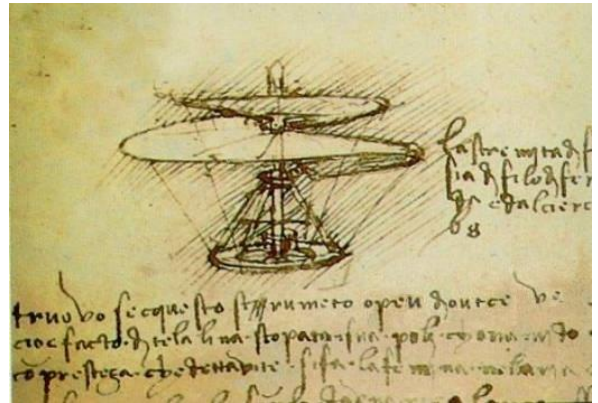

Figure 1.2

Michelangelo produced the preliminary sketch for San Giovanni de’ Florentini in 1559 on paper as shown in Figure 1.3.

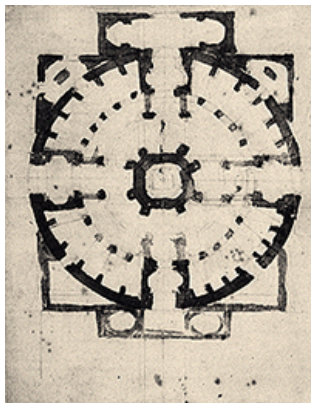

Figure 1.3

During the Industrial Age in the 1850’s drawings became elaborate and were prepared by qualified architects, engineers and draughtsmen and can be seen in Figure 1.4, Robinson’s New York Utility plan showing the sewer, gas, water services and ventilation.

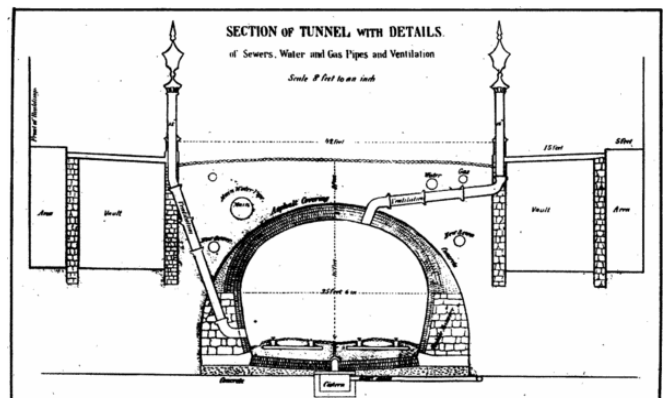

Figure 1.4

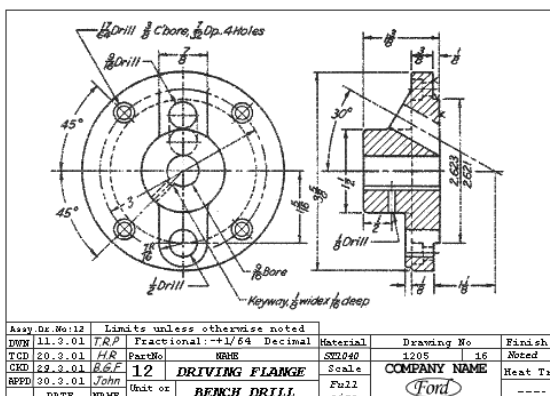

Figure 1.5

Figure 1.5 shows the detail drawing of a Flange drawn by hand in 2001 on tracing paper.

Drawings were created by the designer with little thought to conformity or any standard; some drawings had some dimensions or sizes however many drawings showed the basic shape or overall sizes and the actual details were left up to the engineer and supervisor on the job.



Standards have existed since the beginning of recorded history. The ancient Egyptians developed the 365 day calendar in 4236BC basing the rising of the “Dog Star” or Sirius every 365 days. In 1120AD, King Henry I of England instituted the “ell” which was the equivalent to the length of his arm.

The earliest standards were the physical standards for weights and measures which provided a single reference point and against which all other weights and measures in the society could be standardised. As trade and commerce developed, written documents developed which set down mutually agreed standards for products and services such as shipbuilding, housing, electrical/electronic goods, clothing and nearly any object that has to be manufactured. Initially, the standards were unique documents and formed part of a single contract between the supplier and the purchaser. Later the concept of common standards evolved where the same standard could be used across a range of transactions; this portability offering a uniform set of criteria, is the basis of modern standardisation.

After the rapid industrialisation of the early 19<sup>th</sup> century, the general absence of national standardisation caused high inefficiencies. Lack of conformity was a major cost as evidenced with the different railway gauges between the different states; each carriage had to be unloaded from one carriage in New South Wales and loaded onto another carriage in Victoria when transporting goods between the states. It wasn't until the end of the 19<sup>th</sup> century that the value of standardisation in sizes, specifications, materials, testing and conformance was recognised as a national priority. By 1900, standardisation was flourishing and has continued to where is has now become intrinsic to modern society and has extended far beyond the initial focus to include consumer safety, occupational health and a myriad of other topics, all of which serve to improve the quality and comfort of everyday life.

Standards are the tools we use to organise our technical world and measures we employ to establish norms for management procedures; they underpin consumer expectations that products purchased will be safe, reliable and fit-for-purpose. Standards have become such integral components of our economic, social and legal systems that they are often taken for granted and their crucial role in modern society is often not recognised.<sup>1</sup>

### **Australian Drawing Standards:**

A Standard is a published document which sets out specifications and procedures designed to ensure that a material, product, method or service is fit for its purpose and consistently perform in the way it is intended. Standards establish a common language which defines quality and establishes safe criteria. Standards and conformance are the keys to ensuring the quality and consistency of physical, chemical and biological measurement throughout Australian society and the economy.

The benefit of standards to both the Public and National Interest are:<sup>2</sup>

- Standards Protect Australians.
- Standards Support Australian Innovation.
- Standards Boost Australian Production and Productivity.
- Standards Make Australian Business More Competitive.
- Standards Link Australia to the World.
- Standards Complement Australian Regulation and Make Markets Work Better.
- Working on Australian Standards Rewards Participants.

The Australian Standards applying to the preparation and presentation of drawings in Australia is AS1100 and sets the standard for linework, lettering, dimensioning, symbols, borders, sheet sizes etc.

---

<sup>1</sup> Australian Standards – <http://www.standards.org.au/cat.asp?catid=3>

<sup>2</sup> Australian Standards – <http://www.standards.org.au/cat.asp?catid=2>

**Manual Drafting Equipment:**

The equipment used to produce a drawing depends on the method of drafting being used; i.e. computer, drawing board, photographic etc. Drawings prepared electronically (computers) require little more than a computer, keyboard, monitor, software and a printer/plotter. Drawings being prepared manually varies depending on the medium and methods used. The equipment usually consists of:

**Drawing Board:**

A drawing board is the surface upon which a drawing is prepared. A drawing board can be a simple sheet of plywood with a layer of thick paper or vinyl to allow a good quality line to be drawn or an elaborate drafting machine with movable arms and rules which can be rotated. Most drawing boards are used on a flat table and may be slightly inclined for an easier working position. Drafting machines can be raised or lowered, positioned vertically or horizontally, and some can rotate to allow the draftsman to work upside down at the top of the drawing without having to remove and reposition the drawing.



Drawing Board with T-square



Drafting Machine

Drawing boards and machines have been largely replaced by the computer.

**T-square, Set Squares and Protractor:**

The T-square has a long horizontal arm called the *Blade*, fastened to a shorter vertical arm called the *Head*. The upper edge of the blade and the inner edge of the head are the working edges. The working edge of the blade must be straight or the drawn lines will curve; the head must not be convex or the head will rock and the drawn lines will not be parallel.

Set squares are available in 45° and 30°x60° styles; they are made from transparent plastic which allows lines on the drawing below the set-square to be seen.

Protractors are used for measuring and setting out angles other than those obtainable with the set-squares. Protractors are normally made from transparent plastic similar to set-squares.



T-Square

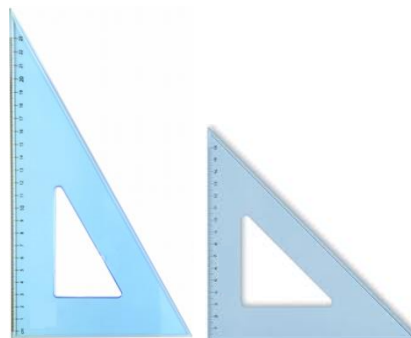

Set Squares

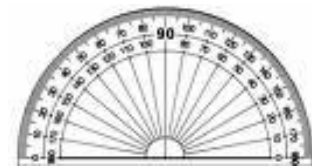

Protractor

**Compass Set:**

A compass has one leg which carries a pencil; the legs are connected by a bow-shaped spring instead of a joint. An adaptor can be inserted into the pencil leg and an ink pen used in place of the pencil. Compasses are used to draw arcs or circles.



Compass Set



Bow Compass

When using the pencil attachment with the compass, the pencil graphite is placed with the bevelled edge on the outside. The pin on the leg is placed at the point where the circle centre is required, the radius is set and the compass rotated about the pin by rotating the handle between the thumb and forefinger.

#### *Technical Pens:*

Technical pens consist of a cone which is a tube with a needle point; inside the pen's body is a reservoir that supplies ink to the cone. Technical pens are available in a large range of standard widths. For optimum line work quality, the cones are manufactured in a variety of materials (mild steel, tungsten tip, ceramic tip) depending on the drawing material being used.



Technical Pen



Pen's Cones

#### *Scale Rule:*

The Scale Rule is similar to a normal rule but is graduated in the metric (or imperial) system to set scales; with practice, using a scale rule is as easy as reading a normal rule. Standard scales used in the scale rule are 1:1, 1:2, 1:5, 1:10, 1:20, 1:50, 1:100, 1:200; 1:500 and larger.

Scale rules can be "flat" or "triangular"; the flat rule has bevelled edges for when using ink.



Flat Scale Rule



Triangle Scale Rule

#### *Pencils:*

High quality pencils should always be used when drawing. Pencils are available in the old style timber pencil or modern technical pencils. The older style timber pencils have a thin rod of graphite in the centre and require constant sharpening to maintain a good sharp point for drawing. Mechanical pens have the graphite inside a tube and as the

point wears down or breaks, more lead can be exposed as required. Mechanical pens are also available in a range of standard widths (0.25mm, 0.35mm, 0.5mm, 0.7mm, 1mm) which give a constant line width.



Timber Pencil



Mechanical Pencil

When using timber pencils, the pencil should be revolved between the thumb and forefinger to assist in retaining a sharp point; revolving a mechanical pencil is not as important but can assist with maintaining a constant line width.

Pencils are available in a range of grades (or hardness) ranging from 9H to 7B. The 9H pencil has a very hard lead and leaves a very narrow and light line; if the draftsman is not careful, the pencil can act as a knife and cut through the medium. At the opposite end of grades the 7B is very soft and leaves a wide and dark line; lines drawn using softer pencils are easily smudged. The middle range of pencils includes the F and HB grades. The pencils normally used by draftsmen are 3H, 2H, H, F, HB, and B with the H and 2H being the most commonly used.

When using a compass, it is generally accepted to use a lead about 2 grades softer than used when drawing because less pressure is used when drawing a circle using a compass than when drawing a straight line with a pencil.

*Eraser and Erasing Shield:*

Erasers are available in a range of materials, hardness and abrasiveness depending on the type of pencil/ink and the drawing medium. Care must be taken to retain the drawing surface in as good condition as possible – intense erasing will damage the surface and make it unsuitable for drawing or even create a hole.

The erasing shield is made from thin metal sheeting which has a series of different sized holes and slots. The shield is placed over a line to be erased thus protecting most of the other adjoining lines and text.



Eraser



Erasing Shield

*Stencils:*

Stencils are made from transparent plastic sheets which have letters, numbers, or shapes cut out so a pencil or pen can quickly and accurately reproduce the shape. Lettering guides are available in a range of sizes and are specifically suited to pen sizes (0.25 pen for 2.5mm text, 0.35 pen for 3.5mm text, 0.5 pen for 5mm high text etc). Other stencils are available for symbols and appliances in most drafting disciplines, circles, ellipses and squares for mechanical/basic drawing, and electrical, electronic, architectural and structural to name but a few.



Lettering Guide



Circle Template

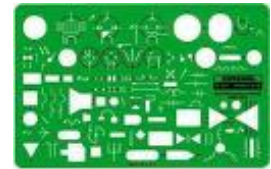

Electrical Template

### **Drawing Media:**

A large variety of drawing mediums are available for producing drawings including Bond Paper, Cartridge Paper, Tracing Paper, Tracing Linen, and Polyester Films and Coated Sheets. Better quality papers are more resilient and stable than the cheaper varieties. As humidity changes, the paper absorbs the moisture in the air and the sheet changes shape and size resulting in inaccurate drawings.

#### ***Bond Paper:***

Bond paper is a highly durable writing paper and having a weight of about 80gm/m<sup>2</sup>. The name comes from it having originally been made for documents such as government bonds. Bond paper is now used for letterheads and other stationary as a paper for electronic printers and plotters but is widely used for graphic work involving pencil, pen and felt-tip markers. Bond paper is made mainly from pulped rag which produces a stronger paper than wood pulp.

#### ***Cartridge Paper:***

Cartridge paper is a high quality type of heavy paper used for illustration and drawing and was originally used for making weaponry cartridges. Cartridge paper used in drawing is slightly more course than bond paper.

#### ***Tracing Paper:***

Tracing paper is translucent and made by immersing good quality paper in sulphuric acid for a few seconds. The acid converts some of the cellulose into amyloid form having a gelatinous and impermeable character; when the paper is dried the resultant product is much stronger than the original paper. Tracing paper is named as such for its ability for an artist to trace an image onto it. When tracing paper is placed onto a picture or drawing, the image is easily viewed through the

Tracing paper is available in grades from the lightweight 42gm/m<sup>2</sup> to the heavyweight 280gm/ m<sup>2</sup>.

#### ***Vellum:***

Vellum can be manufactured from wood pulp or cotton pulp and is used for high quality paper. Vellum is available in a wide range of colours and sizes and can be embossed or plain and is available from 60 to 110gm/ m<sup>2</sup>. Vellum is a good drawing material and is more stable than bond, cartridge and tracing paper.

#### ***Drafting Linen:***

Drafting linen is made from undyed muslin (finely woven) fabric, normally cotton; the cloth was then highly starched and calendered (paper is passed between sever pairs of rollers to give a shiny surface) to create a smooth surface for precise ink and graphite lines. Linen provided an excellent surface for drawing but is highly unstable in humid conditions.

#### ***Polyester Films:***

Polyester drafting film is a highly stable drawing media. The film has a matte finish on the drawing side which provides a good surface for drawing in ink and pencil, and good erasability when using an eraser with little damage to the surface. Film has excellent tensile strength and tear resistance although can be easily ripped if the edge is first nicked. Although the surface feels smooth, film is very abrasive so harder graphite pencils or special plastic pencils, and tungsten or ceramic pens should be used when drawing.

### **Types of Lines:**

A standard system of linetype construction is used on drawings and drawn in 2 line widths or thicknesses, thick and thin. Thick lines include visible outlines, cutting planes and break lines; thin lines include hidden, hatching, extension, centre lines, dimension, break, phantom and existing or adjacent lines. The correct use of linetype allows the tradesperson, architect, engineer or “lay” person to correctly read and interpret the drawing.

#### *Visible Outlines:*

Visible outlines are 0.5mm wide continuous lines and are used to show all edges that are seen by the eye when looking at the object. Only hard knuckle edges are shown, tangents are curves that form a smooth transition and as \_\_\_\_\_ such cannot be seen.

#### *Hidden Outlines:*

A hidden lines are 0.25mm wide dashed lines and show surfaces that cannot be seen. The dashes are the same length and are approximately 3mm long while the gaps are all equal lengths approximately 1mm long. The distances are estimated only and are never measured. The dashes must start and end on a visible \_\_\_\_\_ outline.

#### *Dimension Lines:*

Dimension lines are 0.25mm wide continuous lines and used to show the extent of a dimension. The dimension text appears above the dimension line while a leader is another form of dimension line and used to connect dimensions (radius or diameter) and notes to a drawing feature. \_\_\_\_\_

#### *Projection Lines:*

Projection lines are 0.25mm wide continuous lines and used in conjunction with dimension lines. Projection lines extend from the dimension to the points which the dimension line refers to on the object within the view. \_\_\_\_\_

#### *Centrelines:*

Centrelines are 0.25mm wide and used to locate the centres of holes or circular parts of an object. The line consists of a series of long and short dashes, separated by a gap. The long dashes are approximately 25mm long while the short dashes and gaps are approximately 3mm long each. Like hidden outlines, the distances are estimated only and are never measured. The long dashes start and end approximately 15 to 20mm outside the visible outline. \_\_\_\_\_

Centrelines can also be curved to show the centres of \_\_\_\_\_ holes around a centre point and are referred to on a drawing as PCD meaning Pitch Circle Diameter.

#### *Hatching Lines:*

Section lines are used to show that a surface has been cut in a sectional view. Section lines are drawn 0.25mm wide, parallel, and spaced approximately 3mm apart with the spacing varying according to the material and area to be hatched. Lines are usually drawn at 45° but can also be 30° or 60° depending on the shape of the object.

#### *Cutting Plane:*

The cutting plane shows where a section has been taken \_\_\_\_\_ through an object (where is has been theoretically cut in half to view the inside shape clearly). The line is drawn using a 0.5mm wide continuous line 10mm long and parallel to the cutting plane, and then another 0.5mm wide line 10mm line at right angle to the cutting plane; arrows are placed at the end of this line to identify the direction of viewing the section.

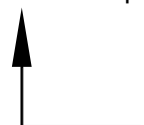

**Break Lines:**

Break lines are used to show that a part of the object has been removed or broken away to show the internal area clearly. Break lines are drawn with 0.25mm continuous lines; the lines may be straight with a "Z" shape in the middle or curved lines.

**Phantom Lines:**

A phantom line shows the position of an object that moves or the extents of the original shape. Phantom lines are 0.25mm wide and drawn using a long dashed line approximately 20mm long, followed by 2 short dashes approximately 3mm long, all separated by 3mm wide gaps.

**Existing or Adjacent Parts:**

Existing or adjacent parts are continuous lines 0.25mm wide and represent any structure or part immediately in the vicinity of the object.

**Typical Example of Types of Line**

Figure 1.6

The drawing shown in Figure 1.6 shows the outline of a Plate with a series of drilled holes. The dimensions are shown as smaller text while the larger text indicates the type of line.

**Orthogonal Projection:**

Orthogonal or Orthographic Projection is a means of representing a three-dimensional object in a two-dimensional plane or space called a view. A number of views can be included on a drawing with each view being positioned to each other using one of two projection methods, third angle projection, or first angle projection.

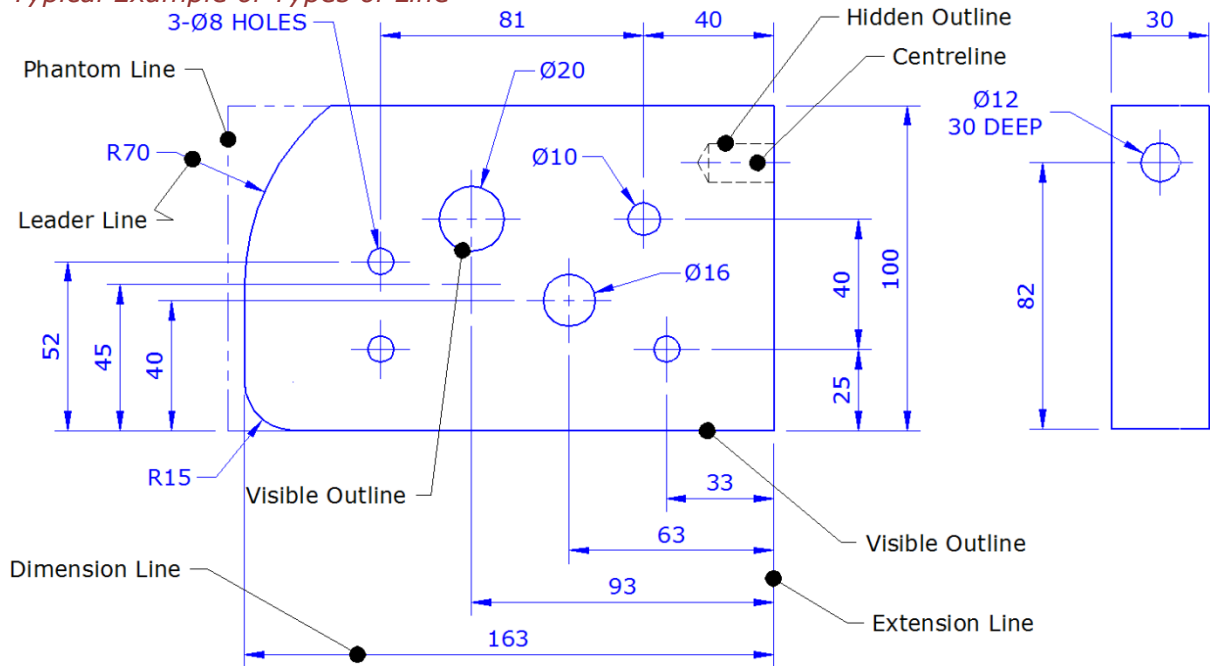
First Angle Projection was the preferred method for drawing for many years however Third Angle Projection proved to be more logical and became the preferred method of projection. In Australia, the method of projection used according to AS1100 is Third Angle Projection.

The rules for Orthogonal Projection are:

- The Top and Bottom Views must be positioned vertically above or below the Front View.
- The Side Views must be positioned horizontally in line with the Front View.
- The height of the Side Views must be the same as the Front View.

- The width of the Side Views must be the same as the Top and/or Bottom Views.
- The views should be evenly spaced over the drawing.

### **Third Angle Projection:**

In Third Angle Projection, the object is fully located in front of the viewing plane; any visible feature is drawn using a continuous outline while any hidden feature is drawn using dashed lines.

**N.B. The view are drawn from where the object is being viewed. View from the Left, drawn on the Left; view from on top, draw the view on the top.**

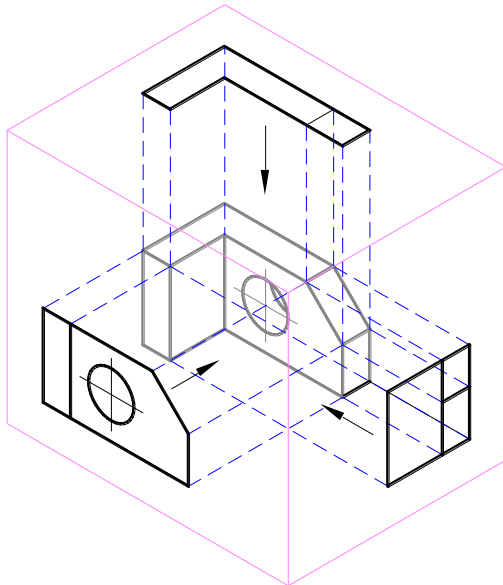

Figure 1.7

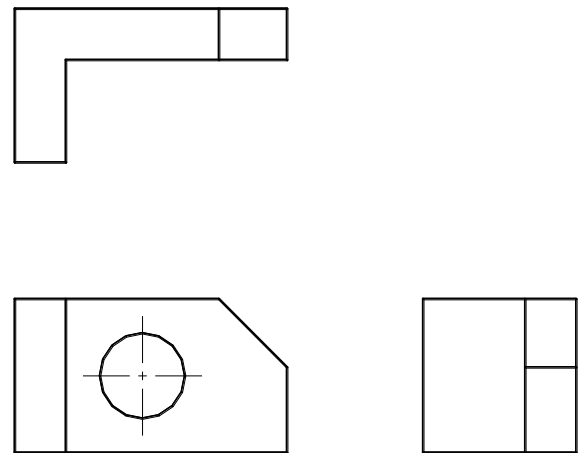

Figure 1.8

In Figure 1.7, the orthogonal planes are represented by the boundary box (magenta lines). The faces of the 3 visible sides have been projected along the dashed lines (blue) and drawn as seen from the viewing direction. In Figure 1.8, the views are shown with the planes opened flat to leave the Front, Right and Top views.

A drawing produced in Third Angle Projection can be identified with the following symbol as shown in Figure 1.9 and to the dimensions shown in Figure 1.10.

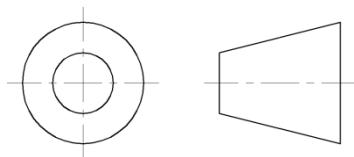

Figure 1.9

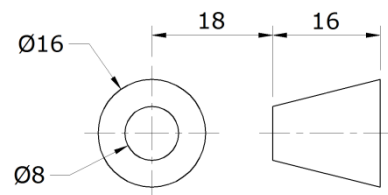

Figure 1.10

### **First Angle Projection:**

In First Angle Projection, the object is fully located behind of the viewing plane; any visible feature is drawn using a continuous outline while any hidden feature is drawn using dashed lines. The shape of the view and the details shown are exactly the same as the view drawn in third angle projection – only the position of the view changes. The view when viewed from the left is drawn on the right while the view from above is drawn below.



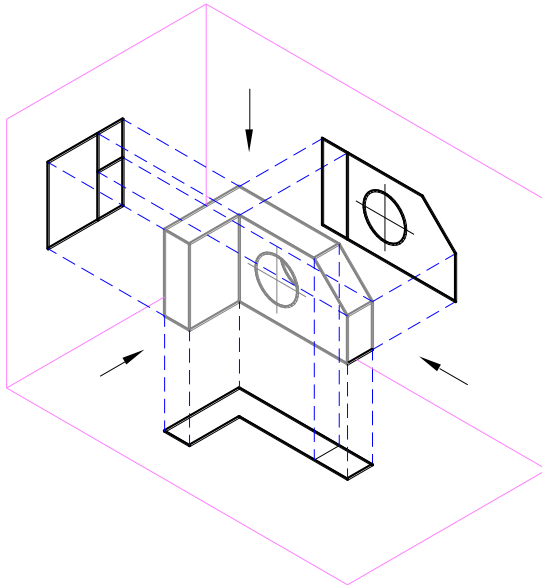

Figure 1.11

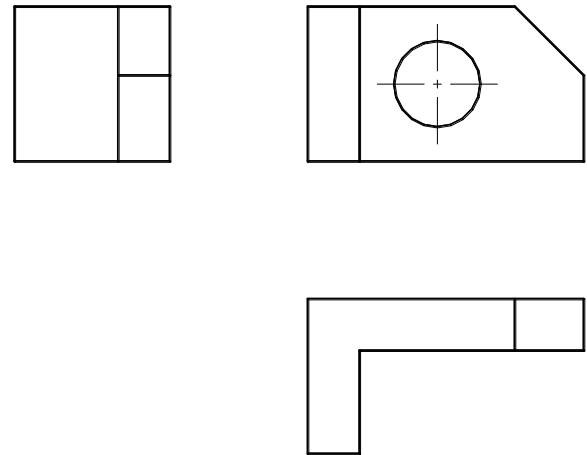

Figure 1.12

In Figure 1.11, the orthogonal planes are represented by the boundary box (magenta lines). The faces of the 3 visible sides have been projected along the dashed lines (blue) and drawn on the other side of the object and the viewing direction. In Figure 1.12, the views are shown with the planes opened flat to leave the Front, Right and Top views but are the direct opposite to that shown in Figure 1.8. The right side view is drawn on the left of the front view while the top view is drawn below the front view.

A drawing produced in First Angle Projection can be identified with the following symbol as shown in Figure 1.13 and to the dimensions shown in Figure 1.14.

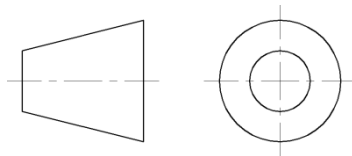

Figure 1.13

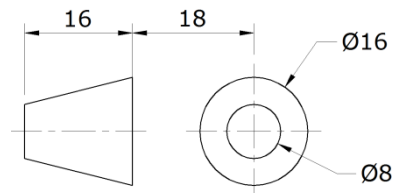
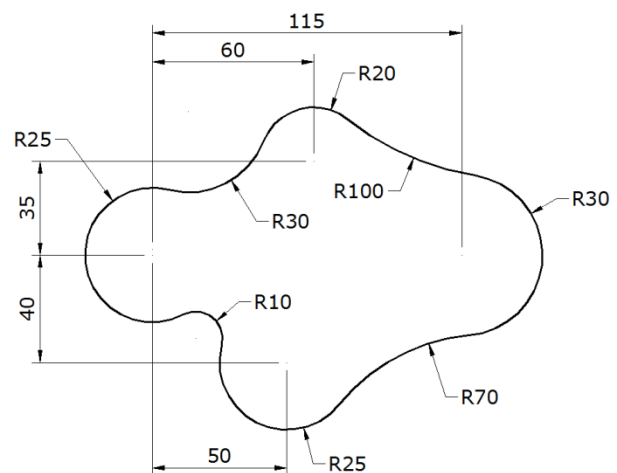

Figure 1.14

### **Number of Views:**

The number of views required depends on the complexity of the component; some drawings may require only one view with the width of the material shown under the Title while other components may require 5 or 6-views to fully describe the object. Figure 1.15 shows a complex cam that requires only 1-view to fully show all the features and dimensions; the thickness is constant and Side View would only show a rectangle so the thickness can be placed below the Title.



MATL: 12PL

Figure 1.15

Figure 1.16 shows a simple hypothetical block with a series of different shape holes; however 5-views are required to fully describe the shape.

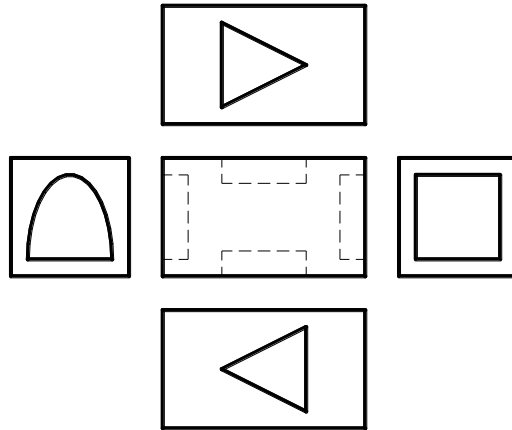

Figure 1.16

Most detail drawing require 3-views to fully display the shape of the component and its dimensions however some components could only require 2-views, especially if it is symmetrical.

**N.B. The number of views depends on the complexity of the object being drawn.**

#### Determining the Front View:

The Front View will display the most detail, or, it is the largest view. Most draftspersons use the largest view because it requires less drawing room to layout the views. To use an example, a detail drawing of a 50mm x 50mm x 8mm thick angle bar, 200 long has to be prepared. If the most detail is the criteria then the 3 views will not fit onto an A4 sheet as can be seen in Figure 1.17. If the criteria used to select the view is the largest view, then the 3 views will fit onto an A4 sheet as can be seen in Figure 1.18 which reduces printing expenses; and smaller sheets are easier to handle on job sites.

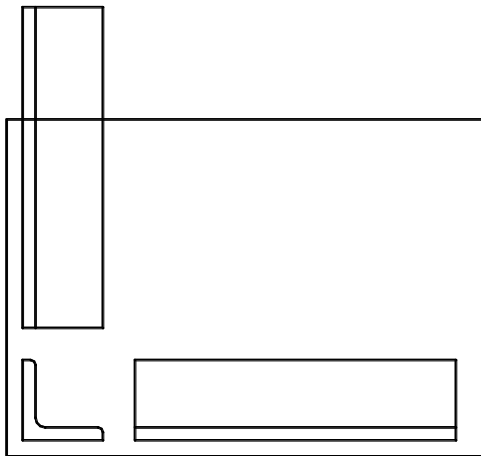

Figure 1.17

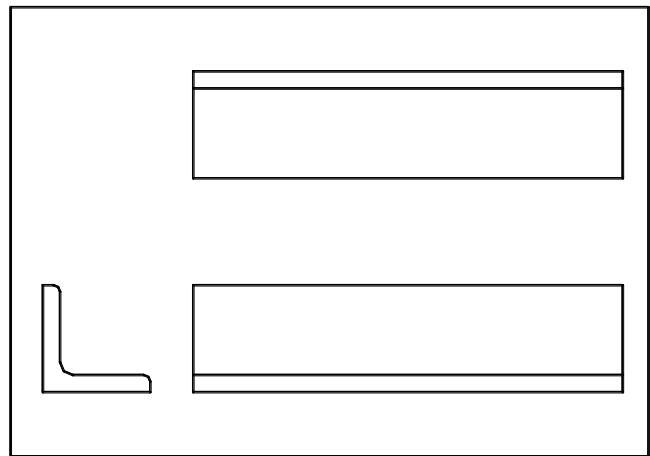

Figure 1.18

When selecting the Front View, the following should also be considered:

- Reduce the number of views required to fully describe the information to be specified.
- Avoid the need for hidden outlines.
- Avoid the unnecessary repetition of detail.

**Skill Practice Exercises:**

*Skill Practice Exercise MEM09204-SP-0101.*

In the space provided, name the type of line indicated

1 \_\_\_\_\_  
 2 \_\_\_\_\_  
 3 \_\_\_\_\_  
 4 \_\_\_\_\_  
 5 \_\_\_\_\_

1 \_\_\_\_\_  
 2 \_\_\_\_\_  
 3 \_\_\_\_\_  
 4 \_\_\_\_\_  
 5 \_\_\_\_\_  
 6 \_\_\_\_\_

1 \_\_\_\_\_  
 2 \_\_\_\_\_  
 3 \_\_\_\_\_  
 4 \_\_\_\_\_

1 \_\_\_\_\_  
 2 \_\_\_\_\_  
 3 \_\_\_\_\_  
 4 \_\_\_\_\_  
 5 \_\_\_\_\_

*Skill Practice Exercise MEM09204-SP-102*

In the space provided, name the type of line indicated.

1 \_\_\_\_\_  
 2 \_\_\_\_\_  
 3 \_\_\_\_\_  
 4 \_\_\_\_\_

1 \_\_\_\_\_  
 2 \_\_\_\_\_  
 3 \_\_\_\_\_  
 4 \_\_\_\_\_  
 5 \_\_\_\_\_

1 \_\_\_\_\_  
 2 \_\_\_\_\_  
 3 \_\_\_\_\_  
 4 \_\_\_\_\_

1 \_\_\_\_\_  
 2 \_\_\_\_\_  
 3 \_\_\_\_\_  
 4 \_\_\_\_\_  
 5 \_\_\_\_\_

*Skill Practice Exercise MEM09204-SP-103*

CAD- Create A new drawing using the template called MEM09204-SP-103 on the network drive and produce the views in Third Angle Projection on the grid supplied. Save the file in your work area as MEM09204-SP-103.

Manual - Sketch the views in Third Angle Projection on the grid supplied.

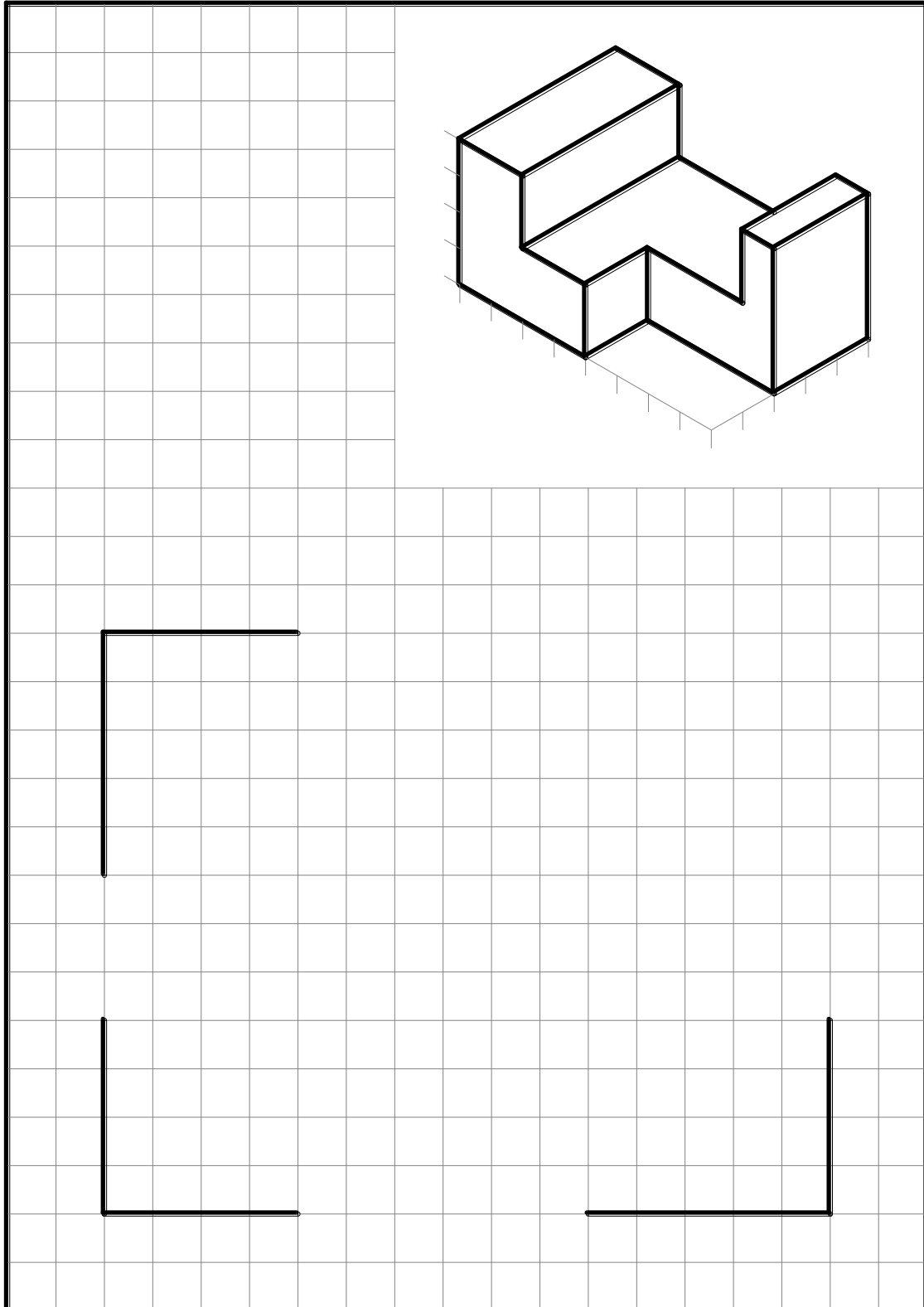

Name: \_\_\_\_\_

*Skill Practice Exercise MEM09204-SP-104*

CAD- Create A new drawing using the template called MEM09204-SP-104 on the network drive and produce the views in Third Angle Projection on the grid supplied. Save the file in your work area as MEM09204-SP-104.

Manual - Sketch the views in Third Angle Projection on the grid supplied.

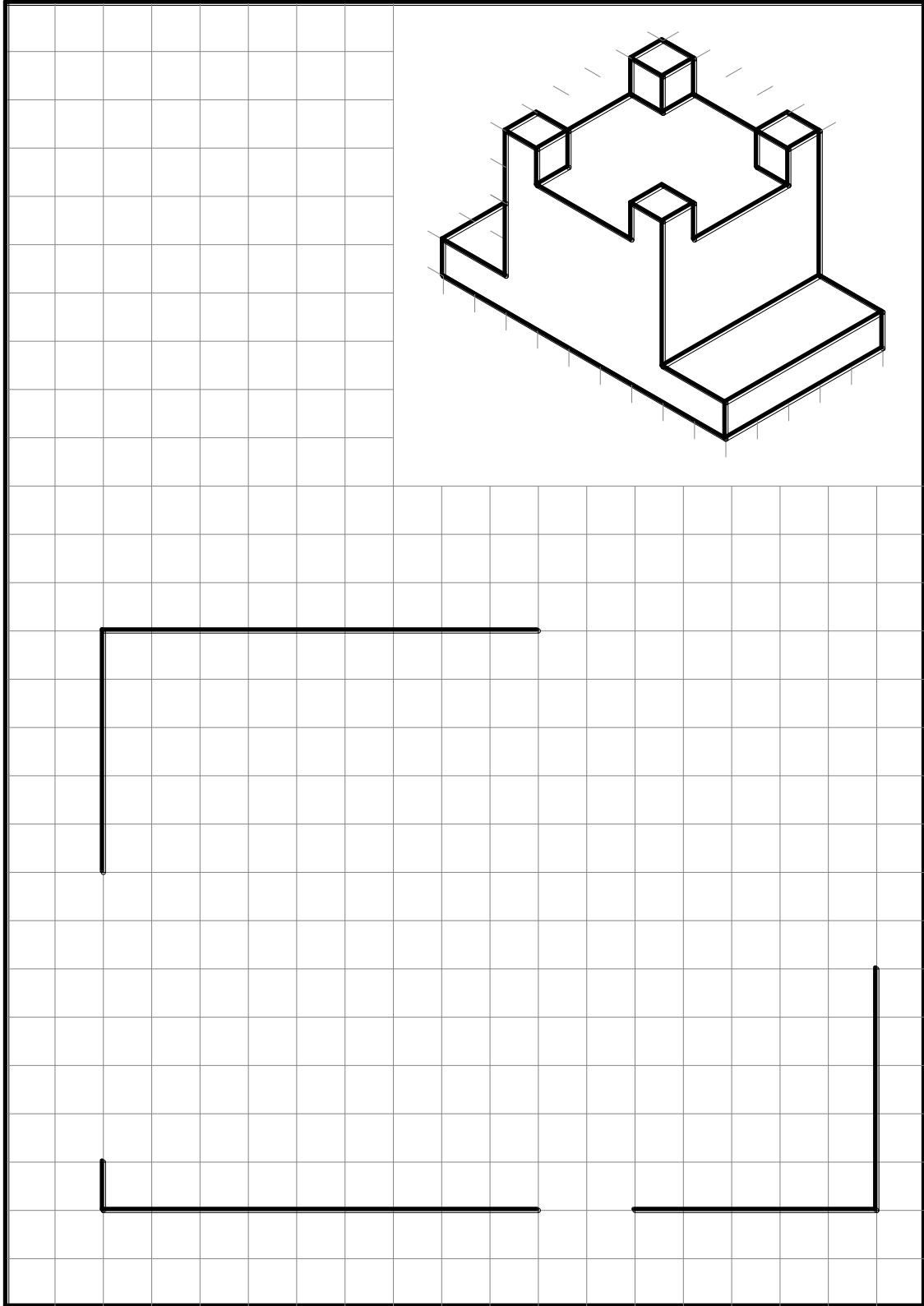

Name: \_\_\_\_\_